

IPU31 series

V1.0

The IPU31 series of AC/DC switching mode power supplies provide 30 Watts of continuous output power. All supplies are UL 94V-1 min compliant. All models meet FCC Part-15 class B and CISPR-22 class B emission limits and are designed to comply with UL/c-UL, TUV/GS and CE marking conformity assessment. All units are 100% burned in and tested.

RoHS2
2011/65/EU



30W External Power Supply for Industrial Purpose

FEATURES:

- * Wide Operating Voltage 80 to 275 VAC, 47 to 63 Hz
- * IEC-320-C14 Input Inlet
- * Optional Output Connector (See page appendix)
- * Single Output
- * Efficiency level V
- * 5 year warranty

APPLICATIONS:

- * Ethernet Hub
- * Portable Devices
- * Charger
- * Monitor
- * Set-top Box
- * AV Equipment

GENERAL SPECIFICATION:

- * **Short Circuit Protection:** Auto Recovery
- * **Cooling:** Free Air Convection
- * **Flammability Rating:** UL94V-1
- * **Protection Classes:** Class I
- * **Safety:** UL 60950-1:2nd Edition, IEC 60950-1:2005 /A2:2013, EN60950-1:2006 /A2:2013, CSA C22.2 No.60950-1-07

APPROVALS:



Electrical Characteristics:

Symbol	Characteristic	Condition	Min.	Typ.	Max.	Unit
Vins	Safety Approval Input Voltage Range	Safety Approval & Specification in Label	100		240	VAC
Vin	Input Operate Voltage Range	Detail to see Fig.1	80		275	VAC
Fi	Input Frequency	Sine wave	47		63	Hz
Po	Output Power Range	See Rating Chart			30	W
Iil	Low Line Input Current	Full Load, Vin=100VAC		0.8		A
Iih	High Line Input Current	Full Load, Vin=240VAC		0.33		A
Irl	Low Line Input Inrush Current	Full Load, 25°C, Cool start, Vin=100VAC			28	A
Irh	High Line Input Inrush Current	Full Load, 25°C, Cool start, Vin=240VAC			68	A
Ik	Safety Ground Leakage Current	Vin=240VAC, Fi=60Hz			0.75	mA
η	Efficiency	Full Load, Vin=230VAC, Detail to see Rating Chart	See Rating Chart			
ΔVoi	Line Regulation	Full Load, Vin=100~120VAC	0.5		1	%
ΔVoL	Load Regulation	Vin=230VAC, 10~90% Load Change at Condition	3		5	%
OLP	Over Load Protection	Recovers automatically after fault condition is removed	110		150	%
ttr	Time of Transient Response	Full Load, Vin=110VAC			4	ms
thu	Hold-Up Time	Full Load, Vin=100VAC	See Rating Chart			
ts	Start-up time	Full Load, Vin=100~240VAC			2	s
Tc	Temperature Coefficient	Full load, Vin=100~240VAC			±0.04	%/°C
HV	Dielectric Withstanding Voltage (P-S)	Primary to Secondary			4242	VDC
Vpg	Dielectric Withstanding Voltage (P-G)	Primary to PE			2121	VDC
EMI	EMC Emission	Compliance to EN55022 (CISPR22)			B	Class

Environmental:

Symbol	Characteristic	Condition	Min.	Typ.	Max.	Unit
To	Operating Temperature	Detail to see Fig.2 (Derate linearly from 100% load at 40°C to 50% load at 70°C)	-20		70	°C
Ts	Storage Temperature	10 ~ 95% RH	-40		85	°C
Ho	Operating Humidity	non-condensing	0		95%	RH
Hs	Storage Humidity		0		95%	RH
ESDa	Electro Static Discharge	Air Discharge, IEC61000-4-2			8	kV
ESDc	Electro Static Discharge	Contact Discharge, IEC61000-4-2			4	kV
MTBF	Mean Time Between Failure	Operating Temperature at 25°C, Calculated per MIL-HDBK-217F	100k			h
ELEV	Operating Altitude (Elevation)	All condition			4000	m
VBR	Vibration	10 ~ 500Hz, 10min./1cycle, 60min. each along X, Y, Z axes			5	G
Vsl	Surge Voltage	Line-Neutral			1	kV
Vsg	Surge Voltage	Line-PE & Neutral-PE			2	kV

IPU31 series

V1.0

30W External Power Supply for Industrial Purpose

SPECIFICATION NOTE :

- Output can provide up to peak load when the power supply starts up. Continuous staying in more than rated load is not allowed.
- At factory, in 60% rated load condition, each output is checked to be within voltage accuracy.
- Line regulation is defined by changing $\pm 10\%$ of input voltage from nominal line at rated load.
- Load regulation is defined by changing $\pm 40\%$ of measured output load from 60% rated load.
- Ripple & noise is measured by using 20MHz bandwidth limited oscilloscope and terminated each output with a 0.47uF capacitor at rated load and nominal line.
- Hold up time is measured from the end of the last charging pulse to the time which the main output drops down to low limit of main output at rated load and nominal line.
- Efficiency is measured at rated load, and nominal line.

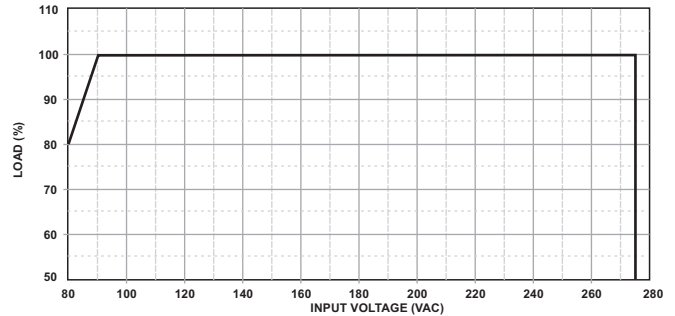

(FIG.1) INPUT VOLTAGE DERATING CURVE

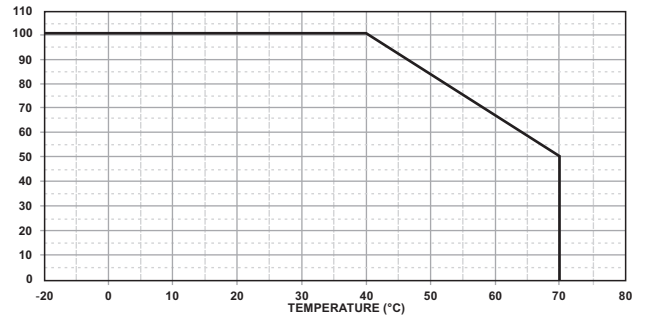

(FIG.2) TEMPERATURE DERATING CURVE

MECHANICAL DIMENSIONS: (UNIT: mm)

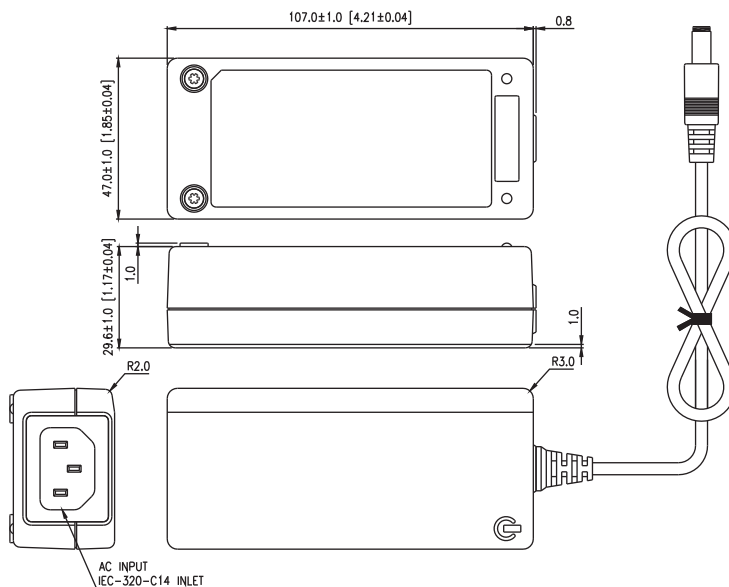

OUTPUT CABLE RECOMMEND :

- Selected output connectors and wire, please refer to Appendix.
- IPU31-101~105 are required to use AWG#16 / 4FT output cable.
- IPU31-106~108 are required to use AWG#18 / 4FT output cable.
- IPU31-109~111 are required to use AWG#18 / 6FT output cable.
- The regulation and efficiency will be changed by modified output cable.

PACKING :

- Net weight: 265~280g approx.
- Optional output connectors available contact sales for details.

Rating Chart:

MODEL NO.	Setting Voltage Range (Factory setting, can't be adjusted)		Output Current (Based on the output volt.)		Maximum Output Power (W)	Ripple & Noise (mVp-p)	Total Regulation (%)	Typ. Efficiency (%)	Typ. No Load Consumption (W)	Hold-Up Time (ms)	Protection Mode
	min	max	min	max							
	(VDC)	(VDC)	(A)	(A)							
IPU31-102	5.0	6.0	3.33	4.00	20	60	± 5	78.6	0.3	12	Hiccup
IPU31-103	6.0	8.0	3.12	4.16	25	80	± 5	82.4	0.3	12	Hiccup
IPU31-104	8.0	11.0	2.72	3.75	30	110	± 5	83.5	0.3	12	Hiccup
IPU31-105	11.0	13.0	2.30	2.72	30	130	± 5	83.5	0.3	12	Hiccup
IPU31-106	13.0	16.0	1.87	2.30	30	150	± 5	83.5	0.3	12	Hiccup
IPU31-107	16.0	21.0	1.42	1.87	30	200	± 5	83.5	0.3	12	Hiccup
IPU31-108	21.0	27.0	1.11	1.42	30	200	± 3	83.5	0.3	12	Hiccup
IPU31-109	27.0	33.0	0.90	1.11	30	300	± 3	83.5	0.3	12	Hiccup
IPU31-110	33.0	40.0	0.75	0.90	30	300	± 3	83.5	0.3	12	Hiccup
IPU31-111	40.0	50.0	0.60	0.75	30	300	± 3	83.5	0.3	12	Hiccup