

DESCRIPTION

The PMP135 series of AC/DC switching power supplies are for 120-135 watts of continuous output power. They are enclosed in a 94V-0 rated polyphenylene-oxide case with an IEC320/C14 or IEC320/C18 inlet to mate with interchangeable cord for world-wide use. All models meet EN55011 and FCC class B emission limits, and are designed for medical applications.

FEATURES

- Low safety ground leakage current
- Wide input range 90 to 264 VAC
- Power factor corrected
- 200% peak power capability on models below 26 Vdc output
- Optional output connectors
- Overvoltage protection
- Over-temperature protection
- Overcurrent protection
- Compliant with CEC and Energy Star Efficiency level V requirements
 - * No load power consumption less than 0.5 W
 - * Average active efficiency greater than 87%
- Compliant with RoHS requirements

INPUT SPECIFICATIONS

Input voltage:	90-264 VAC
Input frequency:	47-63 Hz
Input current:	1.60 A (rms) for 115 VAC 0.80 A (rms) for 230 VAC
Earth leakage current:	200 µA max. @ 264 VAC, 63 Hz
Touch current:	100 µA max. @ 264 VAC, 63 Hz

OUTPUT SPECIFICATIONS

Output voltage /current:	See rating chart.
Maximum output power:	See rating chart.
Ripple and noise:	1% peak to peak maximum at the full load
Overvoltage protection:	Provided and set at 115-140% of its nominal output voltage
Overcurrent protection:	Protected to short circuit conditions
Temperature coefficient:	±0.04% /°C maximum
Transient response:	Maximum excursion of 4% or better on all models, recovering to 1% of final value within 500 us after a 25% step load change

ENVIRONMENTAL SPECIFICATIONS

Operating temperature:	0°C to +60°C
Storage temperature:	-40°C to +85°C
Relative humidity:	5% to 95% non-condensing
Derating:	Derate from 100% at +40°C linearly to 50% at +60°C

PMP135 SERIES



RoHS



SAFETY STANDARD APPROVALS



UL ES 60601-1, CSA C22.2 No. 60601-1
File No. E178020



TÜV EN 60601-1

GENERAL SPECIFICATIONS

Switching frequency:	90-160 KHz
Power factor:	0.98 Typical at 115 VAC
Efficiency:	87% min. at full load
Hold-up time:	15 ms minimum at 110 VAC
Line regulation:	±0.5% maximum at full load
Inrush current:	80 A @ 115 VAC or 160 A @ 230 VAC, at 25°C cold start
Withstand voltage:	5600 VDC from input to output (2 MOPP) 2100 VDC from input to ground (1 MOPP) 700 VDC from output to ground (To verify AC strength, get correct test method to avoid power supply damage.) For Class II models, 4000 VAC from input to output
MTBF:	150,000 hours at full load at 25°C ambient , calculated per MIL-HDBK-217F

EMC Performance (IEC60601-1-2)

EN55011	Class B conducted, class B radiated
FCC:	Class B conducted, class B radiated
VCCI:	Class B conducted, class B radiated
EN61000-3-2:	Harmonic distortion, class A and D
EN61000-3-3:	Line flicker
EN61000-4-2:	ESD, ±15 KV air and ±8 KV contact
EN61000-4-3:	Radiated immunity, 10 V/m
EN61000-4-4:	Fast transient/burst, ±2 KV
EN61000-4-5:	Surge, ±1 KV diff., ±2 KV com
EN61000-4-6:	Conducted immunity, 10 Vrms
EN61000-4-8:	Magnetic field immunity, 30 A/m
EN61000-4-11:	Voltage dip immunity, 30% reduction for 500 ms, 100% reduction for 10 ms

OUTPUT VOLTAGE/CURRENT RATING CHART

Model ⁽¹⁾		Output							Average Active Efficiency (typical) @ 115 / 230 Vac
Class I	Class II	V1	Minimum Current	Maximum Current	Peak current ⁽²⁾	Tol.	Ripple & Noise ⁽³⁾	Max. Power	
PMP135-12	PMP135F-12	12 V	0 A	10.00 A	20.0 A	±5%	120 mV	120 W	87 /89%
PMP135-12-1	PMP135F-12-1	13 V	0 A	9.23 A	18.5 A	±5%	130 mV	120 W	87 /89%
PMP135-13	PMP135F-13	14 V-16 V	0 A	9.29 A	18.6 A	±5%	150 mV	130 W	87 /89%
PMP135-13-1	PMP135F-13-1	18 V-19 V	0 A	7.50 A	15.0 A	±5%	180 mV	135 W	87 /89%
PMP135-13-3	PMP135F-13-3	20 V-21 V	0 A	6.75 A	13.5 A	±5%	200 mV	135 W	87 /89%
PMP135-14	PMP135F-14	24 V-25 V	0 A	5.63 A	11.3 A	±5%	240 mV	135 W	88 /90%
PMP135-15	PMP135F-15	28 V-29 V	0 A	4.83 A	5.8 A	±5%	280 mV	135 W	88 /90%
PMP135-16	PMP135F-16	30 V-32 V	0 A	4.50 A	5.4 A	±5%	300 mV	135 W	89 /90%
PMP135-17	PMP135F-17	36 V-38 V	0 A	3.75 A	4.5 A	±5%	360 mV	135 W	89 /91%
PMP135-18	PMP135F-18	46 V-50 V	0 A	2.94 A	3.5 A	±5%	480 mV	135 W	90 /91%

NOTES:

- Class I models are equipped with IEC320/C14 inlet, and class II models with IEC320/C18 inlet.
- For 10 seconds maximum, average power not to exceed maximum power rating.
- Ripple and noise is maximum peak to peak voltage value measured at output within 20 MHz bandwidth, at rated line voltage and output load ranges, and with a 10 µF tantalum capacitor in parallel with a 0.1 µF ceramic capacitor across the output.

MECHANICAL SPECIFICATIONS

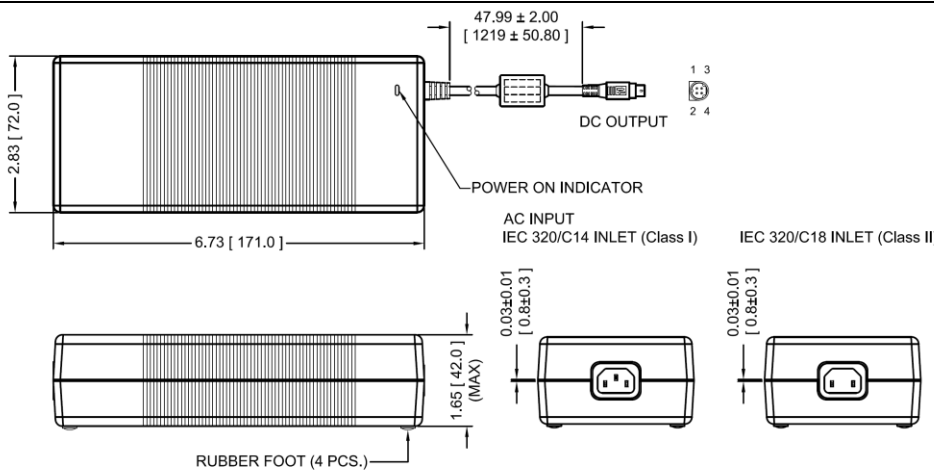

OUTPUT POWER DERATING CURVE

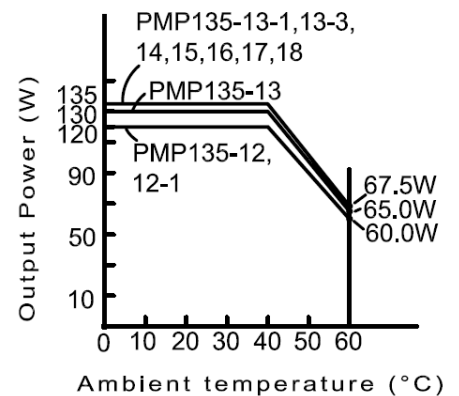

NOTES:

- Dimensions shown in inches [mm]
- Tolerance 0.02 [0.5] maximum
- Weight: 681 grams (1.505 lbs.) approx.
- Refer to Section titled "OPTIONAL OUTPUT CONNECTORS". Add the suffix assigned for a selected connector to a wanted model number, e.g. PMP135-14-B1, for ordering.
- The length of output cable for PMP135-12, PMP135-12-1, PMP135-13, PMP135F-12, PMP135F-12-1, and PMP135F-13 is 37.4 (950)

PIN CHART

MODEL	PIN	1	2	3	4
PMP135-12	PMP135F-12	V1 Return	+V1	V1 Return	+V1
PMP135-12-1	PMP135F-12-1				
PMP135-13	PMP135F-13				
PMP135-13-1	PMP135F-13-1				
PMP135-13-3	PMP135F-13-3				
PMP135-14	PMP135F-14				
PMP135-15	PMP135F-15				
PMP135-16	PMP135F-16				
PMP135-17	PMP135F-17				
PMP135-18	PMP135F-18				