

## FEATURES

- ▶ SMD Package with Industry Standard Pinout
- ▶ Small Footprint:
  - 12.3 x 13.7 mm (0.48" x 0.54") Single Output Models
  - 12.3 x 16.3 mm (0.48" x 0.64") Dual Output Models
- ▶ I/O-Isolation 1500 VDC
- ▶ Single and Dual Output Models
- ▶ Operating Temp. Range -40°C to +85°C
- ▶ Overload Protection
- ▶ High Accuracy of Pin Planarity
- ▶ Qualified for lead-free reflow solder process according IPC/JEDEC J-STD-020D.1
- ▶ Tape & Reel Package available
- ▶ 3 Year Product Warranty

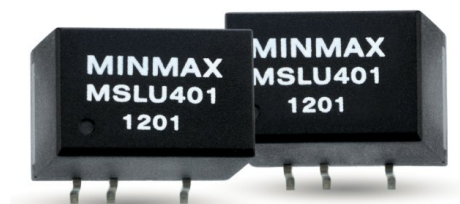

## PRODUCT OVERVIEW

The MINMAX MSLU400 series is a range of 2W DC/DC converters in a SMD- Package featuring I/O-isolation of 1500VDC. The very small footprint makes this product the ideal solution for many applications where a voltage has to be isolated i.e. for noise reduction, ground loop elimination, in digital interfaces or where a converted voltage is required.

An excellent efficiency allows an operating temperature range of -40°C to +85°C. With a new package design these converters are fully qualified for the higher temperature profile used in lead-free reflow solder processes. For automated SMD production lines the product can be supplied in tape & reel package.

### Model Selection Guide

Model Number	Input Voltage (Range) VDC	Output Voltage VDC	Output Current		Input Current		Load Regulation % (max.)	Max. capacitive Load µF	Efficiency (typ.) %
			Max.	Min.	@Max. Load	@No Load			
			mA	mA	mA(typ.)	mA(typ.)			@Max. Load
MSLU401	5 (4.5 ~ 5.5)	3.3	500	10	471	60	11	47	70
MSLU402		5	400	8	548		11	47	73
MSLU404		12	165	3	514		11	10	77
MSLU406		±5	±200	±4	541		10	10#	74
MSLU408		±12	±83	±1.5	524		7	4.7#	76
MSLU409		±15	±66	±1	521		7	4.7#	76
MSLU411	12 (10.8 ~ 13.2)	3.3	500	10	191	30	8	47	72
MSLU412		5	400	8	222		8	47	75
MSLU414		12	165	3	209		5	10	79
MSLU418		±12	±83	±1.5	208		5	4.7#	80
MSLU419		±15	±66	±1	206		5	4.7#	80
MSLU421		3.3	500	10	96		8	47	72
MSLU422	24 (21.6 ~ 26.4)	5	400	8	111	15	8	47	75
MSLU424		12	165	3	105		5	10	79
MSLU428		±12	±83	±1.5	105		5	4.7#	79
MSLU429		±15	±66	±1	104		5	4.7#	79

# For each output

### Input Specifications

Parameter	Model	Min.	Typ.	Max.	Unit
Input Voltage Range	5V Input Models	4.5	5	5.5	VDC
	12V Input Models	10.8	12	13.2	
	24V Input Models	21.6	24	26.4	
Input Surge Voltage (1 sec. max.)	5V Input Models	-0.7	---	9	VDC
	12V Input Models	-0.7	---	18	
	24V Input Models	-0.7	---	30	
Reverse Polarity Input Current	All Models	---	---	0.3	A
Internal Filter Type		Internal Capacitor			
Internal Power Dissipation		---	---	650	mW

### Output Specifications

Parameter	Conditions	Min.	Typ.	Max.	Unit
Output Voltage Balance	Dual Output, Balanced Loads	---	±0.1	±1.0	%
Line Regulation	For Vin Change of 1%	---	±1.2	±1.5	%
Load Regulation	Io=20% to 100%	See Model Selection Guide			
Ripple & Noise	0-20 MHz Bandwidth	---	---	120	mV <sub>P-P</sub>
Temperature Coefficient		---	±0.01	±0.02	%/°C
Short Circuit Protection		0.5 Second Max.			

### General Specifications

Parameter	Conditions	Min.	Typ.	Max.	Unit
I/O Isolation Voltage	60 Seconds	1500	---	---	VDC
I/O Isolation Resistance	500 VDC	1000	---	---	MΩ
I/O Isolation Capacitance	100KHz, 1V	---	60	100	pF
Switching Frequency		50	100	120	KHz
MTBF (calculated)	MIL-HDBK-217F@25°C, Ground Benign	2,000,000			Hours
Moisture Sensitivity Level (MSL)	IPC/JEDEC J-STD-020D.1	Level 2			

### Environmental Specifications

Parameter	Conditions	Min.	Max.	Unit
Operating Ambient Temperature Range (See Power Derating Curve)	Natural Convection	-40	+85	°C
Case Temperature		---	+90	°C
Storage Temperature Range		-50	+125	°C
Humidity (non condensing)		---	95	% rel. H
Cooling	Free-Air convection			
Lead Temperature (1.5mm from case for 10Sec.)		---	300	°C

### Output Voltage Tolerance

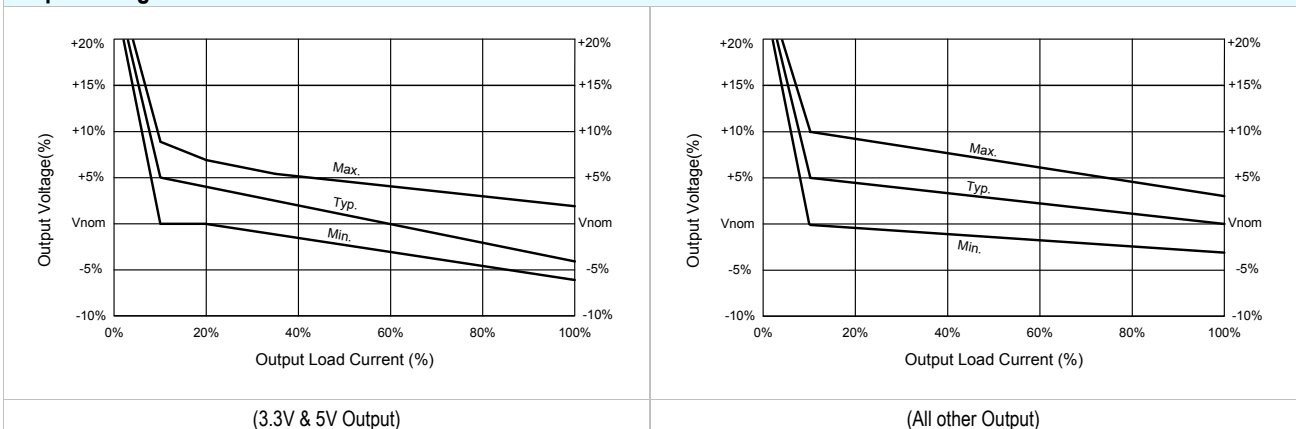

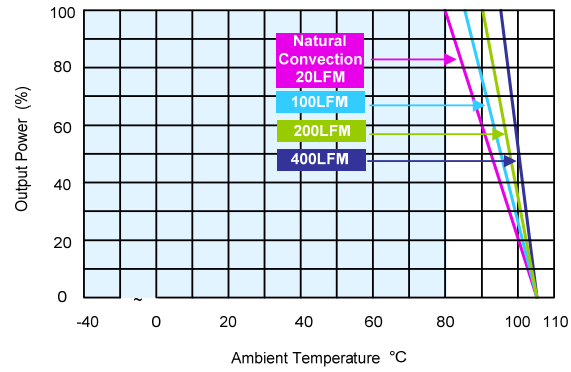
**Power Derating Curve**

**Notes**

- 1 Specifications typical at  $T_a=+25^{\circ}\text{C}$ , resistive load, nominal input voltage and rated output current unless otherwise noted.
- 2 These power converters require a minimum output loading to maintain specified regulation, operation under no-load conditions will not damage these modules; however they may not meet all specifications listed.
- 3 We recommend to protect the converter by a fast blow fuse in the input supply line.
- 4 Other input and output voltage may be available, please contact factory.
- 5 That "natural convection" is about 20LFM but is not equal to still air (0 LFM).
- 6 It is not recommended to use water-washing process on SMT units.
- 7 Specifications are subject to change without notice.

## Package Specifications

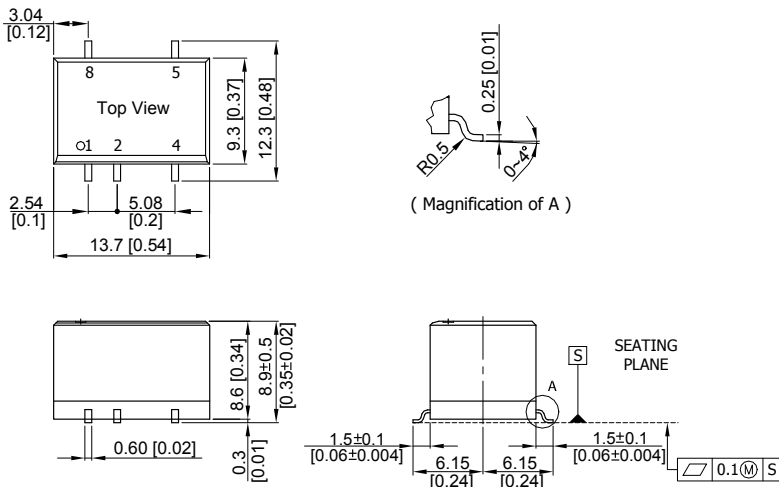
### Mechanical Dimensions (Single Output)



### Connecting Pin Patterns

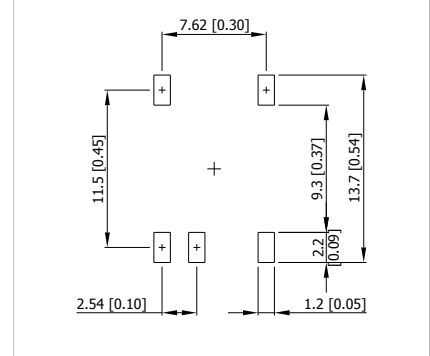

## Package Specifications

### Mechanical Dimensions (Dual Output)

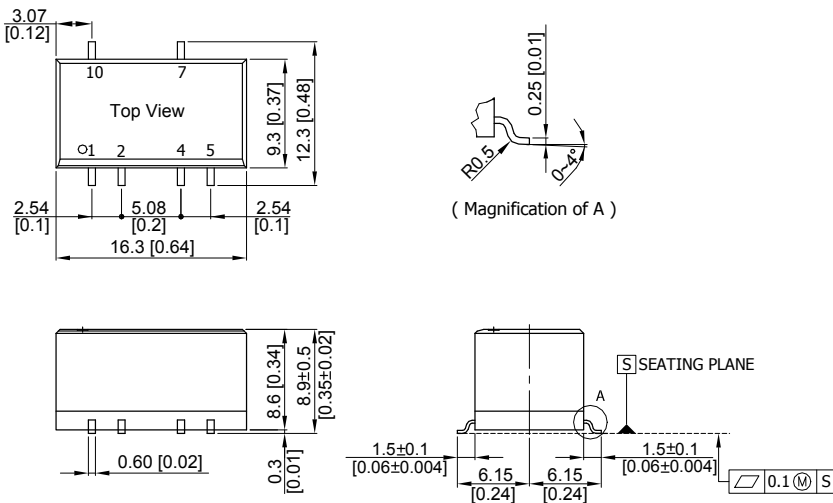

### Connecting Pin Patterns

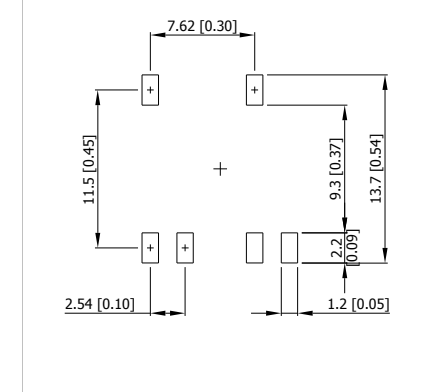

- ▶ All dimensions in mm (inches)
- ▶ Tolerance: X.X±0.25 (X.XX±0.01)  
X.XX±0.13 (X.XXX±0.005)
- ▶ Pins ±0.05(±0.002)

Pin Connections		
Pin	Single Output	Dual Output
1	-Vin	-Vin
2	+Vin	+Vin
4	-Vout	Common
5	+Vout	-Vout
7	No Pin	+Vout
8	NA	No Pin
10	No Pin	NA

NA : Not Available for Electrical Connection

Physical Characteristics	
Case Size (Single Output)	: 13.7x9.3x8.6mm (0.54x0.37x0.34 inches)
Case Size (Dual Output)	: 16.3x9.3x8.6mm (0.64x0.37x0.34 inches)
Case Material	: Non-Conductive Black Plastic (flammability to UL 94V-0 rated)
Pin Material	: phosphor bronze
Weight (Single Output)	: 1.5g
Weight (Dual Output)	: 2.2g

## Test Setup

### Peak-to-Peak Output Noise Measurement Test

Use a  $C_{out}$  0.33 $\mu$ F ceramic capacitor. Scope measurement should be made by using a BNC socket, measurement bandwidth is 0-20 MHz. Position the load between 50 mm and 75 mm from the DC/DC Converter.

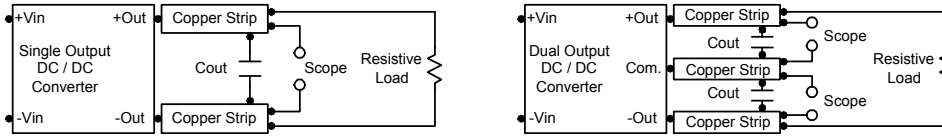

## Technical Notes

### Maximum Capacitive Load

The MSLU400 series has limitation of maximum connected capacitance at the output. The power module may be operated in current limiting mode during start-up, affecting the ramp-up and the startup time. The maximum capacitance can be found in the data sheet.

### Input Source Impedance

The power module should be connected to a low ac-impedance input source. Highly inductive source impedances can affect the stability of the power module. In applications where power is supplied over long lines and output loading is high, it may be necessary to use a capacitor at the input to ensure startup. Capacitor mounted close to the power module helps ensure stability of the unit, it is comended to use a good quality low Equivalent Series Resistance (ESR < 1.0 $\Omega$  at 100 KHz) capacitor of a 2.2 $\mu$ F for the 5V input devices, a 1.0 $\mu$ F for the 12V input devices and a 0.47 $\mu$ F for the 24V devices.

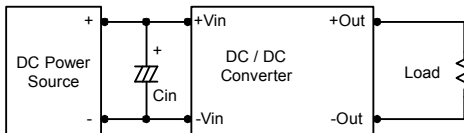

### Output Ripple Reduction

A good quality low ESR capacitor placed as close as practicable across the load will give the best ripple and noise performance. To reduce output ripple, it is recommended to use 1.5 $\mu$ F capacitors at the output.

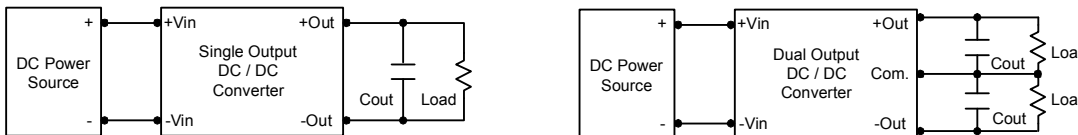

### Thermal Considerations

Many conditions affect the thermal performance of the power module, such as orientation, airflow over the module and board spacing. To avoid exceeding the maximum temperature rating of the components inside the power module, the case temperature must be kept below 90°C. The derating curves are determined from measurements obtained in a test setup.

