

FEATURES

- ▶ Industrial Standard SMD Package
- ▶ I/O Isolation 4000VAC with Reinforced Insulation, rated for 300VAC Working Voltage
- ▶ Low Leakage Current < 2µA
- ▶ Operating Temp. Range -25°C to +80°C
- ▶ Qualified for Lead-free Reflow Solder Process According to IPC/JEDEC J-STD-020D.1
- ▶ Tape & Reel Package Available
- ▶ UL/cUL/IEC/EN 60950-1 Safety Approval
- ▶ Medical Safety meets 2xMOOP per 3rd Edition of IEC/EN 60601-1 & ANSI/AAMI ES60601-1

PRODUCT OVERVIEW

The MINMAX MSHU100 series is a new range of 2W DC/DC-converter modules providing a very high I/O-isolation voltage of 4000 VAC. The product comes in a small SMD-package. There are 15 models available with 5V, 12V or 24VDC input and single-or dual-output voltages.

The MSHU100 DC/DC converters offer an economical solution for many applications in instrumentation, industrial controls, medical equipment and everywhere where a certified supplementary- or reinforced insulation system is required to comply with requested safety standards.

Model Selection Guide

Model Number	Input Voltage (Range) VDC	Output Voltage VDC	Output Current		Input Current		Load Regulation % (max.)	Max. capacitive Load µF	Efficiency (typ.)
			Max.	Min.	@Max. Load	@No Load			@Max. Load
			mA	mA	mA(typ.)	mA(typ.)			%
MSHU102	5 (4.5 ~ 5.5)	5	400	8	606	90	12	330	66
MSHU104		12	165	3	600		10		66
MSHU105		15	133	2.5	605		10		66
MSHU108		±12	±83	±1.5	553		10		72
MSHU109		±15	±66	±1	542		10		73
MSHU112	12 (10.8 ~ 13.2)	5	400	8	253	40	12	330	66
MSHU114		12	165	3	250		10		66
MSHU115		15	133	2.5	252		10		66
MSHU118		±12	±83	±1.5	224		10		74
MSHU119		±15	±66	±1	220		10		75
MSHU122	24 (21.6 ~ 26.4)	5	400	8	126	30	12	330	66
MSHU124		12	165	3	125		10		66
MSHU125		15	133	2.5	126		10		66
MSHU128		±12	±83	±1.5	112		10		74
MSHU129		±15	±66	±1	110		10		75

For each output

Input Specifications

Parameter	Model	Min.	Typ.	Max.	Unit
Input Voltage Range	5V Input Models	4.5	5	5.5	VDC
	12V Input Models	10.8	12	13.2	
	24V Input Models	21.6	24	26.4	
Input Surge Voltage (1 sec. max.)	5V Input Models	-0.7	---	9	VDC
	12V Input Models	-0.7	---	18	
	24V Input Models	-0.7	---	30	
Reverse Polarity Input Current	All Models	---	---	0.3	A
Input Filter		Internal Capacitor			

Output Specifications

Parameter	Conditions	Min.	Typ.	Max.	Unit
Output Voltage Setting Accuracy		---	±2.0	±4.0	%Vnom.
Output Voltage Balance	Dual Output, Balanced Loads	---	±0.1	±1.0	%
Line Regulation	Vin=Min. to Max. @Full Load	---	±1.2	±1.5	%
Load Regulation	Io=20% to 100%	See Model Selection Guide			
Ripple & Noise	0-20 MHz Bandwidth	---	---	150	mV _{P-P}
Temperature Coefficient		---	±0.01	±0.02	%/°C
Short Circuit Protection		0.5 Second Max.			

Isolation, Safety Standards

Parameter	Conditions	Min.	Typ.	Max.	Unit
I/O Isolation Voltage	60 Seconds	4000	---	---	VACrms
I/O Isolation Test Voltage	Flash tested for 1 Second	6000	---	---	V _{PK}
Leakage Current	240VAC, 60Hz	---	---	2	μA
I/O Isolation Resistance	500 VDC	10	---	---	GΩ
I/O Isolation Capacitance	100KHz, 1V	---	15	20	pF
Safety Standards	UL/cUL 60950-1, CSA C22.2 No 60950-1				
	ANSI/AAMI ES60601-1, CAN/CSA-C22.2 No. 60601-1				
	IEC/EN 60950-1, IEC/EN 60601-1 3 rd Edition 2xMOOP				
Approvals	IEC 60950-1 CB Report, UL/cUL 60950-1 certificate				
	IEC 60601-1 3 rd Edition CB Report, ANSI/AAMI ES60601-1 2xMOOP certificate				

General Specifications

Parameter	Conditions	Min.	Typ.	Max.	Unit
Switching Frequency		50	80	100	KHz
MTBF (calculated)	MIL-HDBK-217F@25°C, Ground Benign	2,000,000			Hours
Moisture Sensitivity Level (MSL)	IPC/JEDEC J-STD-020D.1	Level 2			

Environmental Specifications

Parameter	Conditions	Min.	Max.	Unit
Operating Ambient Temperature Range (See Power Derating Curve)	Natural Convection	-25	+80	°C
Case Temperature		---	+90	°C
Storage Temperature Range		-50	+125	°C
Humidity (non condensing)		---	95	% rel. H
Cooling	Free-Air convection			
Lead Temperature (1.5mm from case for 10Sec.)		---	260	°C

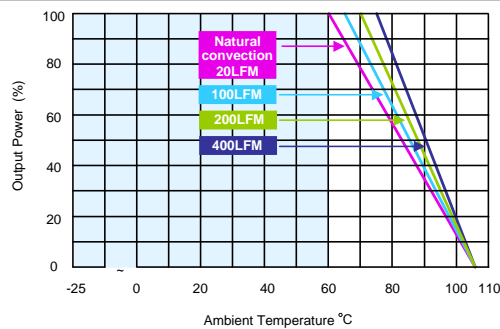
Power Derating Curve

Notes

- 1 Specifications typical at Ta=+25°C, resistive load, nominal input voltage and rated output current unless otherwise noted.
- 2 These power converters require a minimum output loading to maintain specified regulation, operation under no-load conditions will not damage these modules; however they may not meet all specifications listed.
- 3 We recommend to protect the converter by a slow blow fuse in the input supply line.
- 4 Other input and output voltage may be available, please contact factory.
- 5 That "natural convection" is about 20LFM but is not equal to still air (0 LFM).
- 6 It is not recommended to use water-washing process on SMT units.
- 7 Specifications are subject to change without notice.

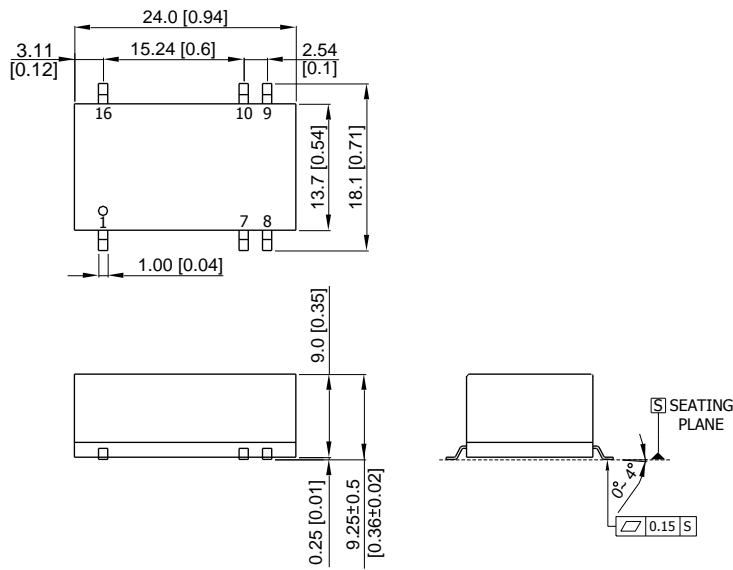
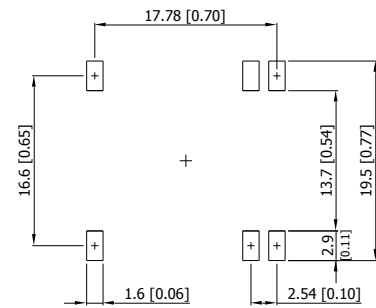
Package Specifications
Mechanical Dimensions

Connecting Pin Patterns

- ▶ All dimensions in mm (inches)
- ▶ Tolerance: X.X±0.5 (X.XX±0.02)
X.XX±0.25 (X.XXX±0.01)
- ▶ Pins ±0.05 (±0.002)

Pin Connections

Pin	Single Output	Dual Output
1	-Vin	-Vin
7	NC	NC
8	NC	Common
9	+Vout	+Vout
10	-Vout	-Vout
16	+Vin	+Vin

NC: No Connection

Physical Characteristics

Case Size	: 24.0x13.7x9.0mm (0.94x0.54x0.35 inches)
Case Material	: Non-Conductive Black Plastic (flammability to UL 94V-0 rated)
Pin Material	: phosphor bronze
Weight	: 3.75g

Test Setup

Peak-to-Peak Output Noise Measurement Test

Use a $0.47\mu\text{F}$ ceramic capacitor. Scope measurement should be made by using a BNC socket, measurement bandwidth is 0-20 MHz. Position the load between 50 mm and 75 mm from the DC/DC Converter.

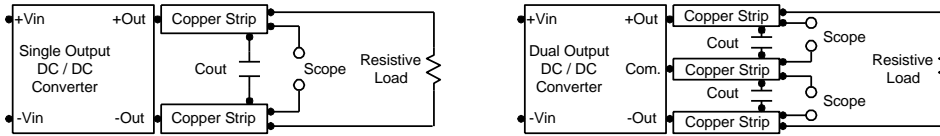

Technical Notes

Maximum Capacitive Load

The MSHU100 series has limitation of maximum connected capacitance at the output. The power module may be operated in current limiting mode during start-up, affecting the ramp-up and the startup time. For optimum performance we recommend $100\mu\text{F}$ maximum capacitive load for dual outputs and $330\mu\text{F}$ capacitive load for single outputs. The maximum capacitance can be found in the data sheet.

Input Source Impedance

The power module should be connected to a low ac-impedance input source. Highly inductive source impedances can affect the stability of the power module. In applications where power is supplied over long lines and output loading is high, it may be necessary to use a capacitor at the input to ensure startup.

Capacitor mounted close to the power module helps ensure stability of the unit, it is recommended to use a good quality low Equivalent Series Resistance (ESR 1.0Ω at 100 KHz) capacitor of a $2.2\mu\text{F}$ for the 5V input devices, a $1.0\mu\text{F}$ for the 12V input devices and a $0.47\mu\text{F}$ for the 24V input devices.

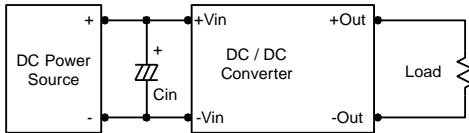

Output Ripple Reduction

A good quality low ESR capacitor placed as close as practicable across the load will give the best ripple and noise performance. To reduce output ripple, it is recommended to use $3.3\mu\text{F}$ capacitors at the output.

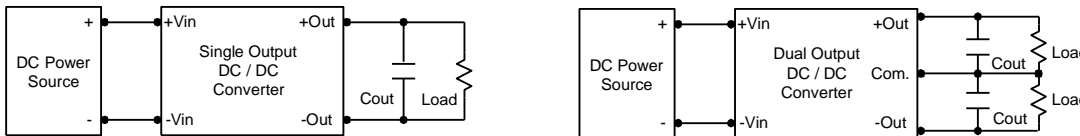

Thermal Considerations

Many conditions affect the thermal performance of the power module, such as orientation, airflow over the module and board spacing. To avoid exceeding the maximum temperature rating of the components inside the power module, the case temperature must be kept below 90°C . The derating curves are determined from measurements obtained in a test setup.

