

## FEATURES

- ▶ High Power Density in SIP-9 Package
- ▶ Small Footprint: 26 x 9.2 mm (1.02" x 0.36")
- ▶ Ultra-wide 4:1 Input Range
- ▶ Fully Regulated Output
- ▶ Operating Temp. Range -40°C to +85°C
- ▶ Overload Protection
- ▶ I/O-Isolation Voltage 1500 VDC
- ▶ Remote On/Off Control
- ▶ 3 Years Product Warranty



## PRODUCT OVERVIEW

The MINMAX MEW1000 series is a range of isolated 2W DC/DC converter modules featuring fully regulated output and ultra-wide 4:1 input voltage ranges. The product comes in a SIP-9 package with a very small footprint occupying only 2.4 cm<sup>2</sup> (0.36 square in.) on the PCB. An excellent efficiency allows an operating temperature range of -40°C to +85°C. Further features include remote On/Off control and over load protection. The very compact dimensions of these DC/DC converters make them an ideal solution for many space critical applications in battery-powered equipment and instrumentation.

### Model Selection Guide

Model Number	Input Voltage (Range) VDC	Output Voltage VDC	Output Current		Input Current		Reflected Ripple Current mA(typ.)	Max. capacitive Load uF	Efficiency (typ.) @Max. Load %
			Max. mA	Min. mA	@Max. Load mA(typ.)	@No Load mA(typ.)			
<b>MEW1021</b>	24 (9 ~ 36)	3.3	500	125	97	20	300	2200	71
<b>MEW1022</b>		5	400	100	110			1000	76
<b>MEW1023</b>		12	167	42	106			170	79
<b>MEW1024</b>		15	134	33	105			110	80
<b>MEW1025</b>		±5	±200	±50	114			470#	73
<b>MEW1026</b>		±12	±83	±21	108			100#	77
<b>MEW1027</b>		±15	±67	±17	106			47#	79
<b>MEW1031</b>	48 (18 ~ 75)	3.3	500	125	49	15	600	2200	70
<b>MEW1032</b>		5	400	100	58			1000	72
<b>MEW1033</b>		12	167	42	54			170	78
<b>MEW1034</b>		15	134	33	54			110	78
<b>MEW1035</b>		±5	±200	±50	60			470#	70
<b>MEW1036</b>		±12	±83	±21	55			100#	76
<b>MEW1037</b>		±15	±67	±17	55			47#	76

# For each output

### Input Specifications

Parameter	Model	Min.	Typ.	Max.	Unit	
Input Surge Voltage (1 sec. max.)	24V Input Models	-0.7	---	50	VDC	
	48V Input Models	-0.7	---	100		
Start-Up Voltage	24V Input Models	4.5	6	8.5		
	48V Input Models	8.5	12	17		
Under Voltage Shutdown	24V Input Models	---	---	8		
	48V Input Models	---	---	16		
Reverse Polarity Input Current	All Models	---	---	0.5		A
Short Circuit Input Power		---	---	1500		mW
Input Filter		Capacitor type				
Internal Power Dissipation		---	---	2500	mW	

### Output Specifications

Parameter	Conditions	Min.	Typ.	Max.	Unit
Output Voltage Accuracy		---	±1.0	±2.0	%
Output Voltage Balance	Dual Output, Balanced Loads	---	±1.0	±2.0	%
Line Regulation	V <sub>in</sub> =Min. to Max.	---	±0.3	±0.5	%
Load Regulation	I <sub>o</sub> =25% to 100%	---	±0.5	±0.75	%
Ripple & Noise (20MHz)		---	30	50	mV <sub>P-P</sub>
Ripple & Noise (20MHz)	Over Line, Load & Temp.	---	---	75	mV <sub>P-P</sub>
Ripple & Noise (20MHz)		---	---	15	mV <sub>rms</sub>
Transient Recovery Time	25% Load Step Change	---	100	300	uS
Transient Response Deviation		---	±3	±5	%
Temperature Coefficient		---	±0.01	±0.02	%/°C
Output Short Circuit	Continuous				

### General Specifications

Parameter	Conditions	Min.	Typ.	Max.	Unit
I/O Isolation Voltage (rated)	60 Seconds	1500	---	---	VDC
I/O Isolation Resistance	500 VDC	1000	---	---	MΩ
I/O Isolation Capacitance	100KHz, 1V	---	250	500	pF
Switching Frequency		---	300	---	KHz
MTBF (Calculated)	MIL-HDBK-217F@25°C, Ground Benign	1,000,000	---	---	Hours

### Input Fuse

24V Input Models	48V Input Models
350mA Slow-Blow Type	135mA Slow-Blow Type

### Remote On/Off Control

Parameter	Conditions	Min.	Typ.	Max.	Unit
Converter On	Under 0.6 VDC or Open Circuit, drops down to 0VDC by 2mV/°C				
Converter Off	2.9 to 15 VDC				
Standby Input Current		---	1	3	mA
Control Input Current ( on )	V <sub>in</sub> = 0V	---	---	-1	mA
Control Input Current ( off )	V <sub>in</sub> = 5.0V	---	---	1	mA
Control Common	Referenced to Negative Input				

### Environmental Specifications

Parameter	Conditions	Min.	Max.	Unit
Operating Temperature Range (with Derating)	Ambient	-40	+85	°C
Case Temperature		---	+90	°C
Storage Temperature Range		-55	+105	°C
Humidity (non condensing)		---	95	% rel. H
Cooling	Free-Air convection			
Lead Temperature (1.5mm from case for 10Sec.)		---	260	°C

### Power Derating Curve

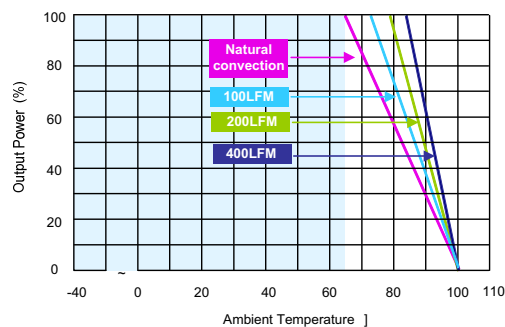

**Notes**

- 1 Specifications typical at Ta=+25°C, resistive load, nominal input voltage and rated output current unless otherwise noted.
- 2 Transient recovery time is measured to within 1% error band for a step change in output load of 75% to 100%.
- 3 Ripple & Noise measurement bandwidth is 0-20 MHz.
- 4 These power converters require a minimum output loading to maintain specified regulation, operation under no-load conditions will not damage these modules; however, they may not meet all specifications listed.
- 5 All DC/DC converters should be externally fused at the front end for protection.
- 6 Other input and output voltage may be available, please contact factory.
- 7 Specifications subject to change without notice.

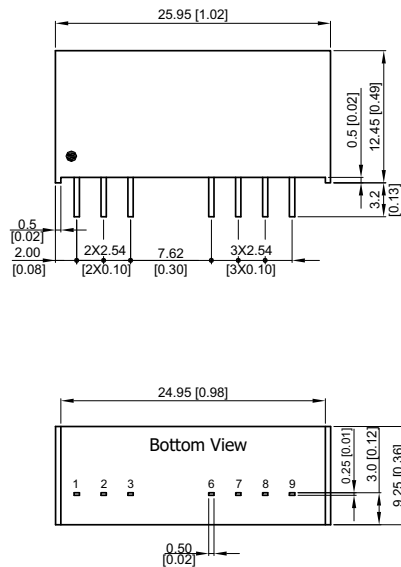
**Package Specifications**
**Mechanical Dimensions**

**Pin Connections**

Pin	Single Output	Dual Output
1	-Vin	-Vin
2	+Vin	+Vin
3	Remote On/Off	Remote On/Off
6	+Vout	+Vout
7	NC	Common
8	NC	NC
9	-Vout	-Vout

NC: No Connection

- ▶ All dimensions in mm (inches)
- ▶ Tolerance: X.X±0.5 (X.XX±0.02)  
X.XX±0.25 (X.XXX±0.01)
- ▶ Pins ±0.1(±0.004)

**Physical Characteristics**

Case Size	:	25.95x9.25x12.45 mm (1.02x0.36x0.49 inches)
Case Material	:	Non-Conductive Black Plastic (flammability to UL 94V-0 rated)
Weight	:	6.5g

## Test Configurations

### Input Reflected-Ripple Current Test Setup

Input reflected-ripple current is measured with an inductor  $L_{in}$  (4.7uH) and  $C_{in}$  (220uF, ESR < 1.0Ω at 100 KHz) to simulate source impedance. Capacitor  $C_{in}$ , offsets possible battery impedance.

Current ripple is measured at the input terminals of the module, measurement bandwidth is 0-500 KHz.

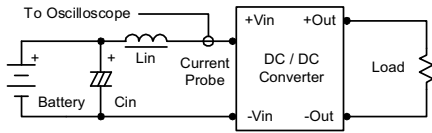

### Peak-to-Peak Output Noise Measurement Test

Use a  $C_{out}$  0.47uF ceramic capacitor. Scope measurement should be made by using a BNC socket, measurement bandwidth is 0-20 MHz. Position the load between 50 mm and 75 mm from the DC/DC Converter.

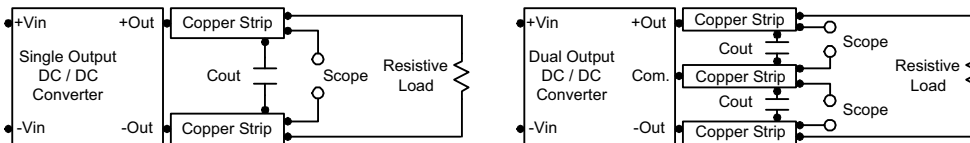

## Design & Feature Considerations

### Remote On/Off

Negative logic remote on/off turns the module off during a logic high voltage on the remote on/off pin, and on during a logic low. To turn the power module on and off, the user must supply a switch to control the voltage between the on/off terminal and the -Vin terminal. The switch can be an open collector or equivalent.

A logic high is 2.9V to 15V. A logic low is under 0.6 VDC or open circuit, drops down to 0VDC by 2mV/°C. The maximum sink current at on/off terminal during a logic low is 1 mA. The maximum allowable leakage current of the switch at on/off terminal (under 0.6VDC or open circuit) is 1mA.

### Maximum Capacitive Load

The MEW1000 series has limitation of maximum connected capacitance at the output. The power module may be operated in current limiting mode during start-up, affecting the ramp-up and the startup time. The maximum capacitance can be found in the data sheet.

### Overcurrent Protection

To provide protection in a fault (output overload) condition, the unit is equipped with internal current limiting circuitry and can endure current limiting for an unlimited duration. At the point of current-limit inception, the unit shifts from voltage control to current control. The unit operates normally once the output current is brought back into its specified range.

### Input Source Impedance

The power module should be connected to a low ac-impedance input source. Highly inductive source impedances can affect the stability of the power module.

In applications where power is supplied over long lines and output loading is high, it may be necessary to use a capacitor on the input to insure startup.

By using a good quality low Equivalent Series Resistance (ESR < 1.0Ω at 100 kHz) capacitor of a 1.5uF for the 24V and 48V devices, capacitor mounted close to the power module helps ensure stability of the unit.

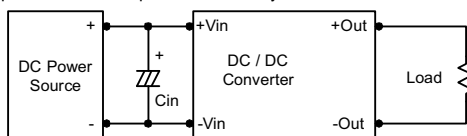

### Output Ripple Reduction

A good quality low ESR capacitor placed as close as practicable across the load will give the best ripple and noise performance. To reduce output ripple, it is recommended to use 3.3uF capacitors at the output.

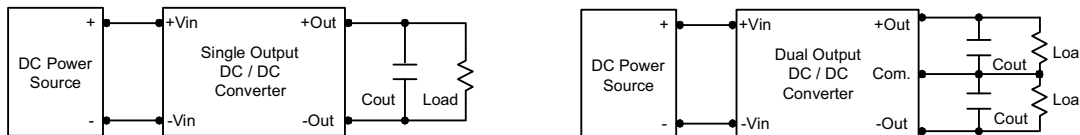

### Thermal Considerations

Many conditions affect the thermal performance of the power module, such as orientation, airflow over the module and board spacing. To avoid exceeding the maximum temperature rating of the components inside the power module, the case temperature must be kept below 90°C. The derating curves are determined from measurements obtained in a test setup.

