

HBU58 series

V1.1

The HBU58 series of AC/DC switching mode power supplies provide 60 Watts of continuous output power. All supplies are UL94V-1 min compliant. All models meet FCC Part-18, CISPR-11 and EN55011 class B emission Limits, IEC 60601-1-2:2014 and are designed to comply with UL/cUL, TUV T-mark and conformity assessment in CE marking. All units are 100% burned in and tested.

RoHS2
2011/65/EU

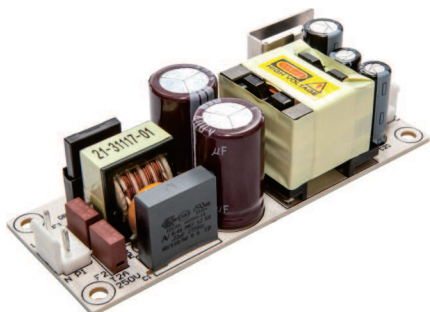

60W Open Frame Medical Grade Power Supply

FEATURES:

- * Wide Operating Voltage, 80 to 275 VAC, 47 to 63 Hz
- * Single Output
- * Over Voltage Protection
- * Input to Output : 2MOPP
- * High ESD immunity
- * Suitable professional healthcare facility
- * 3 year warranty



APPLICATIONS:

- * Breathing Therapy Device
- * Blood Pressure system
- * Portable medical device
- * ECG、EEG
- * Medical Tablet

GENERAL SPECIFICATION:

- * **Short Circuit Protection:** Auto Recovery
- * **Cooling:** Free Air Convection
- * **Flammability Rating:** UL94V-1
- * **Protection Classes:** Class I
- * **Safety:** IEC60601-1 Edition3.1, ES60601-1:2005(R2012), CSAC22.2 NO.60601-1:14, EN60601-1:2006/A1:2013

APPROVALS:



Electrical Characteristics:

Symbol	Characteristic	Condition	Min.	Typ.	Max.	Unit
Vins	Safety Approval Input Voltage Range	Safety Approval & Specification in Label	100		240	VAC
Vin	Input Operate Voltage Range	Detail to see Fig.1 (Derate linearly from 100% load at 90VAC to 80% load at 80VAC)	80		275	VAC
Fi	Input Frequency	Sine wave	47		63	Hz
Po	Output Power Range	See Rating Chart			60	W
Iil	Low Line Input Current	Full Load, Vin=100VAC		1.2		A
Iih	High Line Input Current	Full Load, Vin=240VAC		0.6		A
Irl	Low Line Input Inrush Current	Full Load, 25°C, Cool start, Vin=100VAC			30	A
Irh	High Line Input Inrush Current	Full Load, 25°C, Cool start, Vin=240VAC			60	A
Ik	Safety Ground Leakage Current	Vin=240VAC, Fi=60Hz			0.25	mA
η	Efficiency	Full Load, Vin=230VAC, Detail to see Rating Chart	See Rating Chart			
ΔVoi	Line Regulation	Full Load, Vin=100~120VAC or 200~240VAC			1	%
OVP	Over Voltage Protection		110		275	%
OLP	Over Load Protection	Recovers automatically after fault condition is removed	110		150	%
ttr	Time of Transient Response	Io=Full Load to Half Load, Vin=110VAC			4	ms
thu	Hold-Up Time	Full Load, Vin=100VAC	See Rating Chart			
ts	Start-up time	Full Load, Vin=100~240VAC	0.25		0.5	s
Ris	Insulation Resistance		50			MΩ
Tc	Temperature Coefficient	All Condition			±0.04	%/°C
HV	Dielectric Withstanding Voltage (P-S)	Primary to Secondary, limit current <10mA			4000	VAC
Vpg	Dielectric Withstanding Voltage (P-G)	Primary to PE, limit current <10mA			1500	VAC
EMI	EMC Emission	Compliance to EN55011 (CISPR11), EN60601-1-2	B			Class

Environmental:

Symbol	Characteristic	Condition	Min.	Typ.	Max.	Unit
To	Operating Temperature	Detail to see Fig.2 (Derate linearly from 100% load at 40°C to 50% load at 70°C)	-10		70	°C
Ts	Storage Temperature	10 ~ 95% RH	-40		85	°C
Ho	Operating Humidity	non-condensing	0		95%	RH
Hs	Storage Humidity		0		95%	RH
ESDa	Electro Static Discharge	Air Discharge, IEC61000-4-2			15	kV
ESDc	Electro Static Discharge	Contact Discharge, IEC61000-4-2			8	kV
MTBF	Mean Time Between Failure	Operating Temperature at 25°C, Calculated per MIL-HDBK-217F	200k			h
ELEV	Operating Altitude (Elevation)	All condition			3000	m
VBR	Vibration	10 ~ 500Hz, 10min./1cycle, 60min. each along X, Y, Z axes			5	G
Vsl	Surge Voltage	Line-Neutral			1	kV
Vsg	Surge Voltage	Line-PE & Neutral-PE			2	kV

HBU58 series

V1.1

60W Open Frame Medical Grade Power Supply

SPECIFICATION NOTE :

- Output can provide up to peak load when the power supply starts up. Continuous staying in more than rated load is not allowed.
- At factory, in 60% rated load condition, each output is checked to be within voltage accuracy.
- Line regulation is defined by changing $\pm 10\%$ of input voltage from nominal line at rated load.
- Load regulation is defined by changing $\pm 40\%$ of measured output load from 60% rated load.
- Ripple & noise is measured by using 20MHz bandwidth limited oscilloscope and terminated each output with a 0.47uF capacitor at rated load and nominal line.
- Hold up time is measured from the end of the last charging pulse to the time which the main output drops down to low limit of main output at rated load and nominal line.
- Efficiency is measured at rated load, and nominal line.

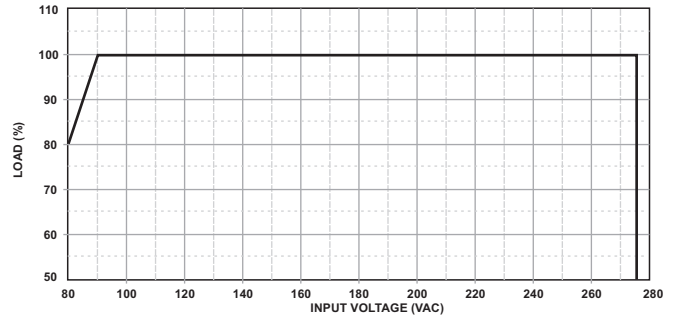

(FIG.1) INPUT VOLTAGE DERATING CURVE

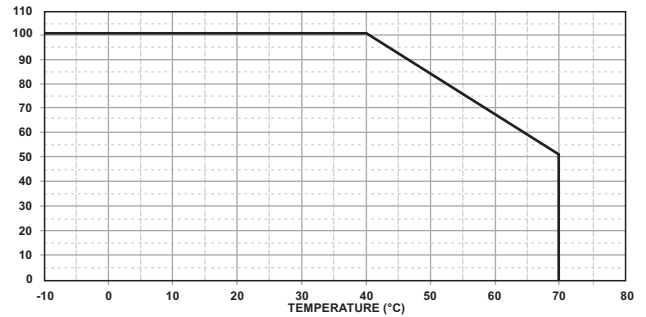

(FIG.2) TEMPERATURE DERATING CURVE

MECHANICAL DIMENSIONS: (UNIT: mm)

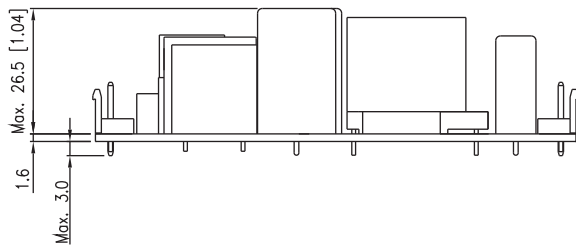
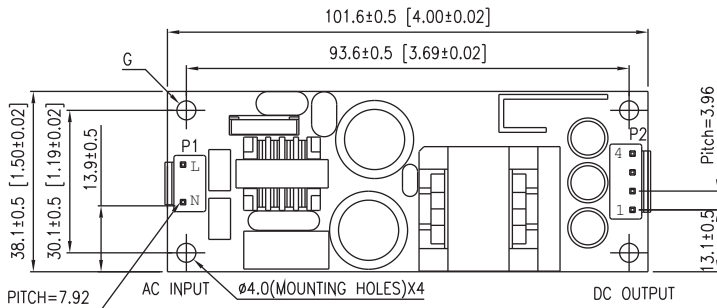

PACKING :

- Net weight: 140g approx.
- Input connector mates with JST housing VHR-3N and series crimp terminal.
- Output connector mates with JST housing VHR-4N and JST SVH series crimp terminal.

PIN CHART

MODEL	PIN	1	2	3	4
HBU58-1XX		RTN	RTN	OUT	OUT

Rating Chart:

MODEL NO.	Setting Voltage Range (Factory setting, can't be adjusted)		Output Current (Based on the output volt.)		Maximum Output Power (W)	Ripple & Noise (mVp-p)	Total Regulation (%)	Typ. Efficiency (%)	Typ. No Load Consumption (W)	Hold-Up Time (ms)	Protection Mode
	min	max	min	max							
	(VDC)	(VDC)	(A)	(A)							
HBU58-102	5.0	6.0	5.50	6.60	33	100	± 5	80	0.5	12	Hiccup
HBU58-103	6.0	8.0	5.00	6.66	40	100	± 5	82	0.5	12	Hiccup
HBU58-104	8.0	11.0	4.54	6.25	50	100	± 5	86	0.5	12	Hiccup
HBU58-105	11.0	13.0	4.61	5.45	60	100	± 5	87	0.5	12	Hiccup
HBU58-106	13.0	16.0	3.75	4.67	60	100	± 5	87	0.5	12	Hiccup
HBU58-107	16.0	21.0	2.85	3.75	60	100	± 5	87	0.5	12	Hiccup
HBU58-108	21.0	27.0	2.22	2.85	60	200	± 3	88	0.5	12	Hiccup
HBU58-109	27.0	33.0	1.81	2.22	60	200	± 3	88	0.5	12	Hiccup
HBU58-110	33.0	40.0	1.50	1.81	60	200	± 3	89	0.5	12	Hiccup
HBU58-111	40.0	50.0	1.20	1.50	60	200	± 3	90	0.5	12	Hiccup
HBU58-112	50.0	55.0	1.09	1.20	60	200	± 3	90	0.5	12	Hiccup