

MBU 153 SERIES

150W Open Frame Switching Power Supplies For Medical Equipment.

Description:

The MBU153 series of compact, open frame constructed, AC/DC switching mode power supplies provide 150 Watts of continuous output power. They are suited for use in hospital instrument and many other applications. All models meet FCC Part-18 class B and CISPR-11 EN55011 class B emission Limits and are designed to comply with ANSI/AAMI ES 60601-1: 2005(UL/cUL 3rd Edition) and new CE requirements. All units are 100% burned in and tested.

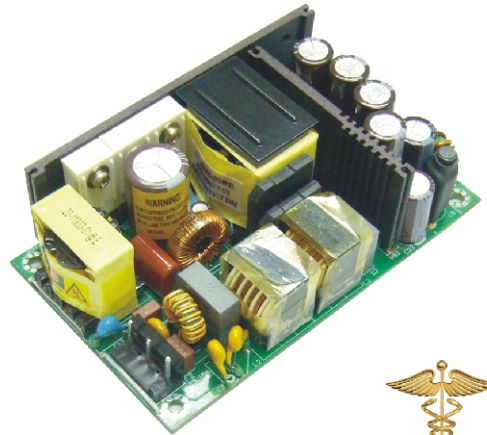

Features:

- Wide Input Voltage 100 to 240 VAC, 47 to 63 Hz
- Internal EMI filter
- Single Output
- Input connector mates with Molex housing 09-50-3051 and Molex 2478 series crimp terminal
- Output connector mates with Molex housing 09-50-3081 and Molex 2478 series crimp terminal
- Input Surge Current, Over Voltage and Over Load protection
- Output Voltage Protection(Crowbar Design)
- Active Power Factor Correction
- Size: 3"x5"x1.44"
- Class I
- 3 year warranty

Safety Approvals :



Electrical Characteristics:

Sym.	Parameter	Test Conditions	Min.	Typ.	Max.	Unit
V _{in}	Input Voltage	Operating Voltage	100		240	VAC
f _{in}	Input Frequency		47		63	Hz
PF	Power Factor Correction	I _o =Full load, V _{in} =100~240VAC	0.95	0.97	1.0	
P _o	Output Power Range	V _{in} =100 to 240 VAC	0		150	W
V _o	Output Voltage Range		See rating Chart			V
I _o	Output Current Range		See rating Chart			A
I _{il}	Input Current (Low Line)	I _o =Full load, V _{in} =115VAC			2	A
I _{ih}	Input Current (High Line)	I _o =Full load, V _{in} =230VAC			1.0	A
I _{rl}	Low Line Inrush Current	I _o =Full load, 25°C, Cool start, V _{in} =115VAC		28	31	A
I _{rh}	High Line Inrush Current	I _o =Full load, 25°C, Cool start, V _{in} =230VAC		57	63	A
Eff	Efficiency	I _o =Full load, V _{in} =230VAC	82	85	87	%
REG-i	Line Regulation	I _o =Full load		0.5	1	%
REG-o	Load Regulation	V _{in} =230VAC		3	5	%
OVP	Over Voltage Protection		112		132	%
OCP	Over Current Protection		110		150	%
T _{tr}	Time of Transient Response	I _o =Full load to Half Load, V _{in} =100VAC			4	mS
Thold	Hold-Up Time	I _o =Full load, V _{in} =110VAC	16			mS
T _s	Start Up Time	I _o =Full load, V _{in} =100VAC			2	S
V _{p-p}	Ripple & Noise (Peak to Peak)	Full load, V _{in} =90VAC		0.5	1	%
I _{lk}	Safety Ground Leakage Current	I _o =Full load, V _{in} =240VAC		0.075	0.1	mA
TC	Temperature Coefficient	All output	-0.04		0.04	%/°C

Environmental :

Sym.	Parameter	Test Conditions	Min.	Typ.	Max.	Unit
T _{oper}	Operating Temperature		0	50	70	°C
T _{stg}	Storage Temperature		-40		85	°C
H _o	Operating Humidity		0		95	%
H _r	Storage Humidity		0		95	%
MTBF	Operating Temperature at 25°C, Calculated per MIL-HDBK-217F		0.1M			Hrs
Pd	Derate linearly from 100% load at 50°C to 50% load at 70°C					

MBU153 SERIES

150W Open Frame Switching Power Supplies For Medical Equipment.

Safety Specifications:

Sym.	Parameter	Test Conditions	Min.	Typ.	Max.	Unit
Vps	Dielectric Withstanding Voltage for Primary to secondary	Primary to secondary	5656			VDC
Vpg	Dielectric Withstanding Voltage for Primary to Ground	Primary to ground	2828			VDC
Ris	Isolation Resistance	Test Voltage=500VDC	50			MΩ
CISPR	EMI requirements for CISPR-11	Vin=220VAC	B			CLASS
FCC	EMI requirements for FCC PART-18	Vin=110VAC	B			CLASS

Output Voltage And Current Rating Chart (Single Output) :

Model Number	Output Voltage	Output Current	Total Regulation	Maximum Output Power
MBU153-105	12 VDC	12.50 A	5%	150W
MBU153-108	24 VDC	6.25 A	3%	150W

Mechanical Specifications :

PIN CHART

PIN MODEL	1	2	3	4	5	6	7	8
MBU153-1XX	Vout	Vout	Vout	Vout	RTN	RTN	RTN	RTN

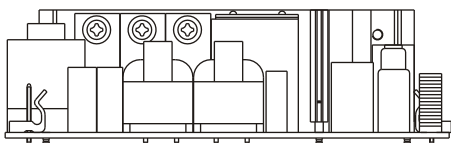
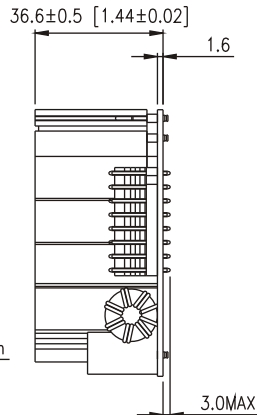
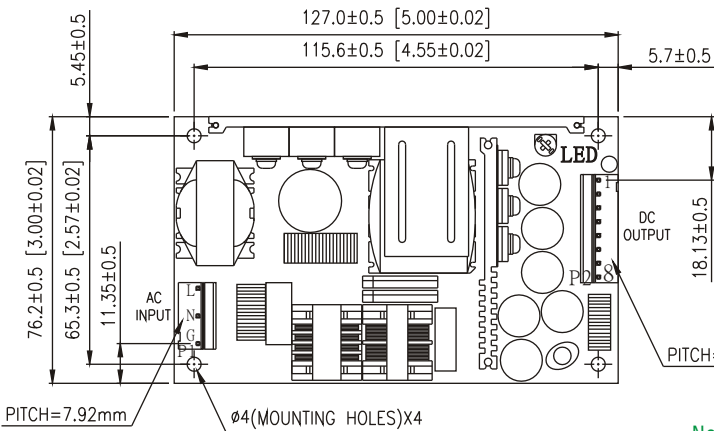
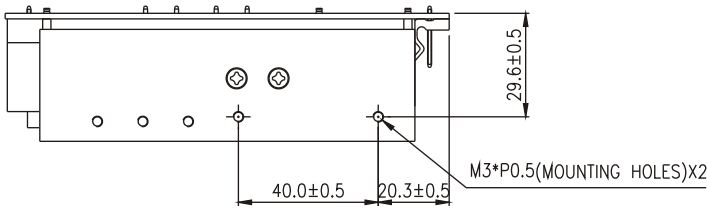

Note:

1. Dimensions are shown in inches or mm.
2. Weight: 420gs approx.
3. Input connector mates with Molex housing 09-50-3051 and Molex 2478 series crimp terminal.
4. Output connector mates with Molex housing 09-50-3081 and Molex 2478 series crimp terminal