

# MCW03 Series

3W, Wide Input Range SIP, Single & Dual Output DC/DC Converters



## Key Features



- High Efficiency up to 83%
- 1600VDC Isolation
- MTBF > 1,000,000 Hours
- 2:1 Wide Input Range
- Low Cost
- Remote On/Off Control
- Temperature Performance  $-40^{\circ}\text{C}$  to  $+70^{\circ}\text{C}$
- UL 94V-0 Package Material
- Internal SMD Construction

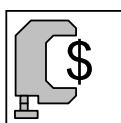

Low Cost

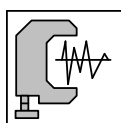

Low Noise

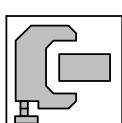

Low Profile

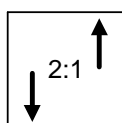

Wide Range

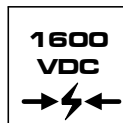

I/O Isolation

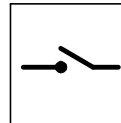

Remote on/off

Minmax's MCW03-Series power modules are low-profile dc-dc converters that operate over input voltage ranges of 4.5–9VDC, 9–18VDC, 18–36VDC and 36–75VDC which provide precisely regulated single output voltages of 3.3V, 5V, 12V, 15V,  $\pm 5\text{V}$ ,  $\pm 12\text{V}$  and  $\pm 15\text{VDC}$ .

The  $-40^{\circ}\text{C}$  to  $+70^{\circ}\text{C}$  operating temperature range makes it ideal for data communication equipments, mobile battery driven equipments, distributed power systems, telecommunication equipments, mixed analog/digital subsystems, process/machine control equipments, computer peripheral systems and industrial robot systems.

The modules have a maximum power rating of 3W and a typical full-load efficiency of 81%, continuous short circuit, 30mV output ripple, built-in filtering for both input and output minimize the need for external filtering.

## Absolute Maximum Ratings

Parameter	Min.	Max.	Unit	
Input Surge Voltage ( 1000 mS )	5VDC Input Models	-0.7	11	VDC
	12VDC Input Models	-0.7	25	VDC
	24VDC Input Models	-0.7	50	VDC
	48VDC Input Models	-0.7	100	VDC
Lead Temperature (1.5mm from case for 10 Sec.)	---	260	$^{\circ}\text{C}$	
Internal Power Dissipation	---	2,500	mW	

Exceeding the absolute maximum ratings of the unit could cause damage. These are not continuous operating ratings.

## Environmental Specifications

Parameter	Conditions	Min.	Max.	Unit
Operating Temperature	Ambient	-40	+70	$^{\circ}\text{C}$
Operating Temperature	Case	-40	+100	$^{\circ}\text{C}$
Storage Temperature		-55	+125	$^{\circ}\text{C}$
Humidity		---	95	%
Cooling	Free-Air Convection			

## Model Selection Guide

Model Number	Input Voltage	Output Voltage	Output Current		Input Current		Efficiency
			Max.	Min.	@Max. Load	@No Load	@Max. Load
	VDC	VDC	mA	mA	mA (Typ.)	mA (Typ.)	% (Typ.)
MCW03-05S033	5 (4.5 ~ 9)	3.3	700	175	651	70	71
MCW03-05S05		5	600	150	822		73
MCW03-05S12		12	250	63	759		79
MCW03-05S15		15	200	50	759		79
MCW03-05D05		±5	±300	±75	811		74
MCW03-05D12		±12	±125	±31	759		79
MCW03-05D15		±15	±100	±25	759		79
MCW03-12S033	12 (9 ~ 18)	3.3	700	175	257	20	75
MCW03-12S05		5	600	150	321		78
MCW03-12S12		12	250	63	301		83
MCW03-12S15		15	200	50	301		83
MCW03-12D05		±5	±300	±75	316		79
MCW03-12D12		±12	±125	±31	301		83
MCW03-12D15		±15	±100	±25	301		83
MCW03-24S033	24 (18 ~ 36)	3.3	700	175	128	10	75
MCW03-24S05		5	600	150	160		78
MCW03-24S12		12	250	63	151		83
MCW03-24S15		15	200	50	151		83
MCW03-24D05		±5	±300	±75	156		80
MCW03-24D12		±12	±125	±31	151		83
MCW03-24D15		±15	±100	±25	151		83
MCW03-48S033	48 (36 ~ 75)	3.3	700	175	64	8	75
MCW03-48S05		5	600	150	80		78
MCW03-48S12		12	250	63	75		83
MCW03-48S15		15	200	50	75		83
MCW03-48D05		±5	±300	±75	78		80
MCW03-48D12		±12	±125	±31	75		83
MCW03-48D15		±15	±100	±25	75		83

## Capacitive Load

Models by Vout	3.3V	5V	12V	15V	±5V #	±12V #	±15V #	Unit
Maximum Capacitive Load	1760	1000	170	110	470	100	47	uF

# For each output

## Input Fuse Selection Guide

5V Input Models	12V Input Models	24V Input Models	48V Input Models
2000mA Slow – Blow Type	1000mA Slow – Blow Type	500mA Slow – Blow Type	250mA Slow – Blow Type

## Input Specifications

Parameter	Model	Min.	Typ.	Max.	Unit
Start Voltage	5V Input Models	3	4	4.5	VDC
	12V Input Models	4.5	7	9	
	24V Input Models	8	12	18	
	48V Input Models	16	24	36	
Under Voltage Shutdown	5V Input Models	---	3.5	4	
	12V Input Models	---	6.5	8.5	
	24V Input Models	---	11	17	
	48V Input Models	---	22	34	
Reverse Polarity Input Current	All Models	---	---	1	A
Short Circuit Input Power		---	---	2500	mW
Input Filter		Capacitor type			

## Output Specifications

Parameter	Conditions	Min.	Typ.	Max.	Unit
Output Voltage Accuracy	Full Load and Nominal Vin	---	±0.5	±1	%
Output Voltage Balance	Dual Output, Balanced Loads	---	±0.5	±2.0	%
Line Regulation	Vin=Min. to Max.	---	±0.3	±0.5	%
Load Regulation	Io=25% to 100%	---	±0.5	±1.0	%
Ripple & Noise (20MHz)		---	50	75	mV P-P
Ripple & Noise (20MHz)	Over Line, Load & Temp.	---	---	100	mV P-P
Ripple & Noise (20MHz)		---	---	15	mV rms
Over Power Protection		120	---	---	%
Transient Recovery Time	25% Load Step Change	---	300	500	uS
Transient Response Deviation		---	±3	±5	%
Temperature Coefficient		---	---	±0.02	%/°C
Output Short Circuit	Continuous				

## General Specifications

Parameter	Conditions	Min.	Typ.	Max.	Unit
Isolation Voltage Rated	60 Seconds	1600	---	---	VDC
Isolation Voltage Test	Flash Tested for 1 Second	1760	---	---	VDC
Isolation Resistance	500VDC	1000	---	---	MΩ
Isolation Capacitance	100KHz, 1V	---	60	200	pF
Switching Frequency		---	300	---	KHz
MTBF	MIL-HDBK-217F @ 25°C, Ground Benign	1000	---	---	K Hours

## Remote On/Off Control

Parameter	Conditions	Min.	Typ.	Max.	Unit
DC/DC On	Under 0.6 VDC or Open Circuit, drops down to 0VDC by 2mV/°C				
DC/DC Off	2.7 to 15 VDC				
Control Input Current ( on )	Vctrl = 0V	---	---	1	mA
Control Input Current ( off )	Vctrl = 5.0V	---	---	1	mA
Control Common	Referenced to Negative Input				
Standby Input Current		---	1	2.5	mA

## Notes:

1. Specifications typical at  $T_a=+25^{\circ}\text{C}$ , resistive load, nominal input voltage, rated output current unless otherwise noted.
2. Transient recovery time is measured to within 1% error band for a step change in output load of 75% to 100%.
3. Ripple & Noise measurement bandwidth is 0–20 MHz.
4. These power converters require a minimum output loading to maintain specified regulation.
5. Operation under no-load conditions will not damage these modules; however, they may not meet all specifications listed.
6. All DC/DC converters should be externally fused at the front end for protection.
7. Other input and output voltage may be available, please contact factory.
8. Specifications subject to change without notice.

## Block Diagram

### Single Output

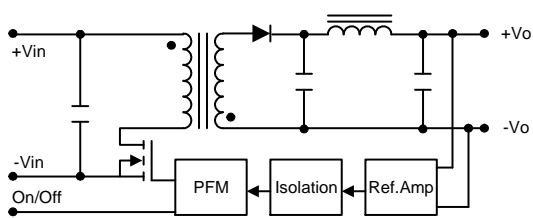

### Dual Output

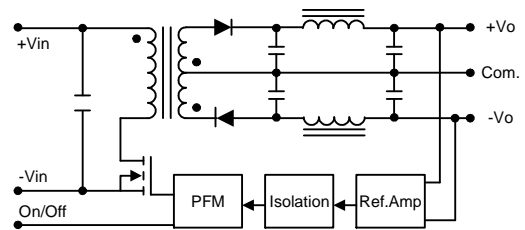

# MCW03 Series

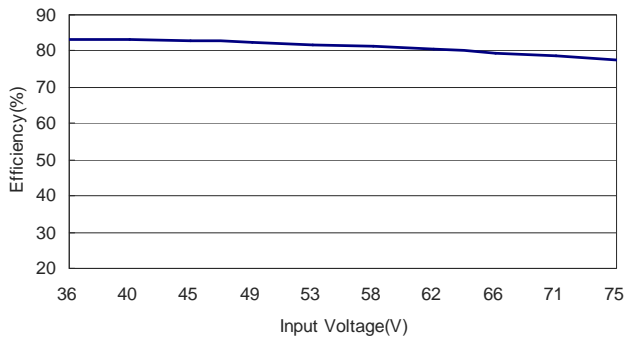

Efficiency vs Input Voltage ( MCW03-48S05 )

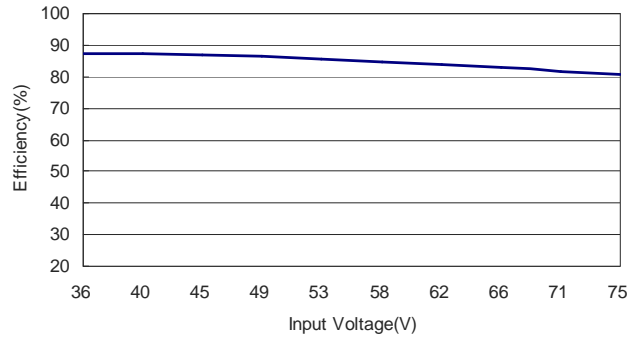

Efficiency vs Input Voltage ( MCW03-48D15 )

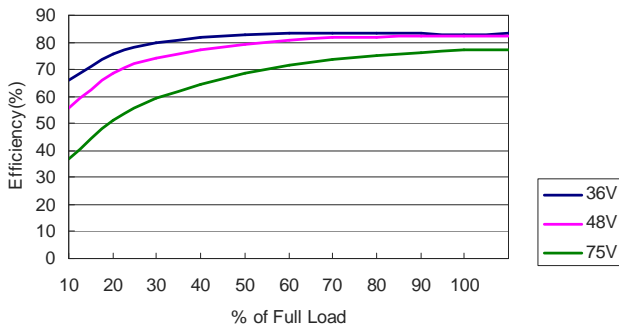

Efficiency vs Output Load ( MCW03-48S05 )

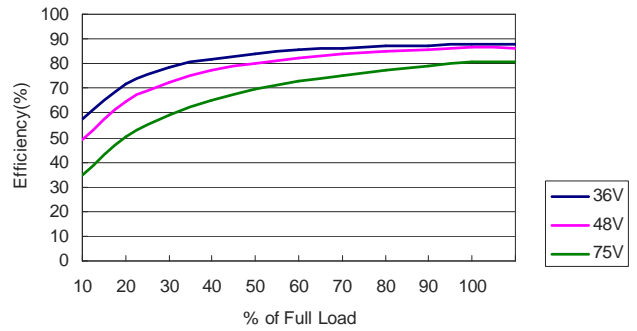

Efficiency vs Output Load ( MCW03-48D15 )

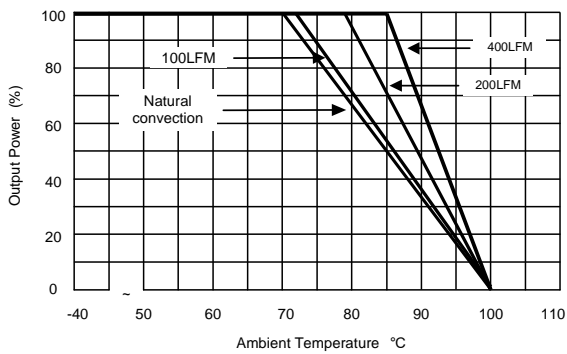

Derating Curve

## Test Configurations

### Input Reflected-Ripple Current Test Setup

Input reflected-ripple current is measured with an inductor  $L_{in}$  (4.7 $\mu$ H) and  $C_{in}$  (220 $\mu$ F, ESR < 1.0 $\Omega$  at 100 KHz) to simulate source impedance.

Capacitor  $C_{in}$ , offsets possible battery impedance.

Current ripple is measured at the input terminals of the module, measurement bandwidth is 0–500 KHz.

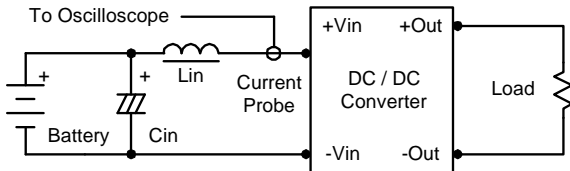

### Peak-to-Peak Output Noise Measurement Test

Use a  $C_{out}$  0.47 $\mu$ F ceramic capacitor.

Scope measurement should be made by using a BNC socket, measurement bandwidth is 0–20 MHz. Position the load between 50 mm and 75 mm from the DC/DC Converter.

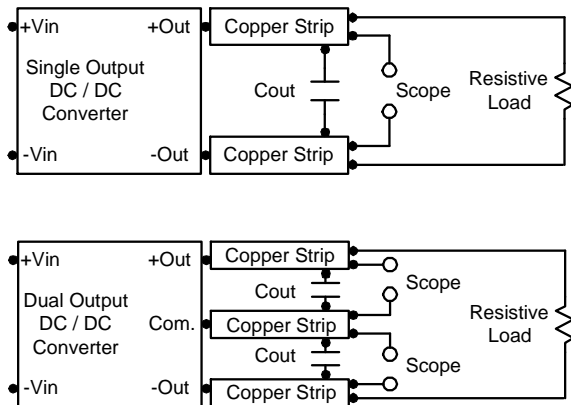

## Design & Feature Considerations

### Remote On/Off

Negative logic remote on/off turns the module off during a logic high voltage on the remote on/off pin, and on during a logic low.

To turn the power module on and off, the user must supply a switch to control the voltage between the on/off terminal and the  $-V_{in}$  terminal.

The switch can be an open collector or equivalent.

A logic high is 2.7V to 15V.

A logic low is under 0.6 VDC or open circuit, drops down to 0VDC by 2mV/°C

The maximum sink current at on/off terminal during a logic low is 1 mA.

The maximum allowable leakage current of the switch at on/off terminal= (under 0.6VDC or open circuit) is 1mA.

### Maximum Capacitive Load

The MCW03 series has limitation of maximum connected capacitance at the output.

The power module may be operated in current limiting mode during start-up, affecting the ramp-up and the startup time.

The maximum capacitance can be found in the data sheet.

### Overcurrent Protection

To provide protection in a fault (output overload) condition, the unit is equipped with internal current limiting circuitry and can endure current limiting for an unlimited duration. At the point of current-limit inception, the unit shifts from voltage control to current control. The unit operates normally once the output current is brought back into its specified range.

### Input Source Impedance

The power module should be connected to a low ac-impedance input source. Highly inductive source impedances can affect the stability of the power module.

In applications where power is supplied over long lines and output loading is high, it may be necessary to use a capacitor at the input to ensure startup.

Capacitor mounted close to the power module helps ensure stability of the unit, it is recommended to use a good quality low Equivalent Series Resistance (ESR < 1.0 $\Omega$  at 100 KHz) capacitor of a 8.2 $\mu$ F for the 5V input devices, a 3.3 $\mu$ F for the 12V input devices and a 1.5 $\mu$ F for the 24V and 48V devices.

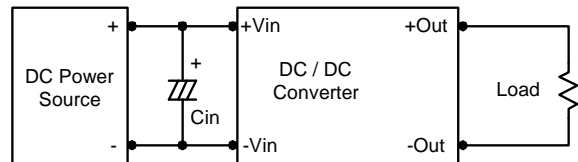

## Output Ripple Reduction

A good quality low ESR capacitor placed as close as practicable across the load will give the best ripple and noise performance.

To reduce output ripple, it is recommended to use 3.3uF capacitors at the output.

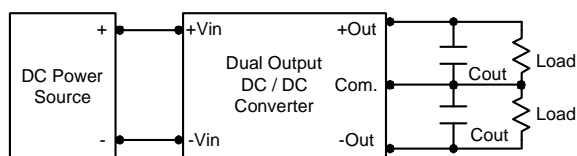
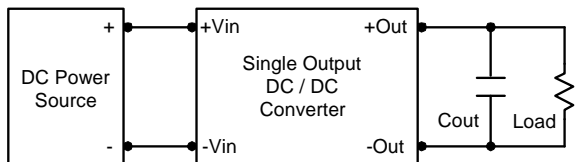

## Thermal Considerations

Many conditions affect the thermal performance of the power module, such as orientation, airflow over the module and board spacing. To avoid exceeding the maximum temperature rating of the components inside the power module, the case temperature must be kept below 90°C.

The derating curves are determined from measurements obtained in an experimental apparatus.

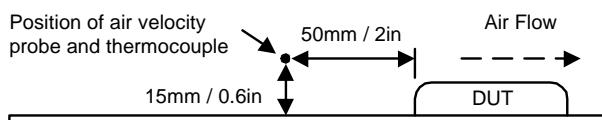

## Mechanical Dimensions

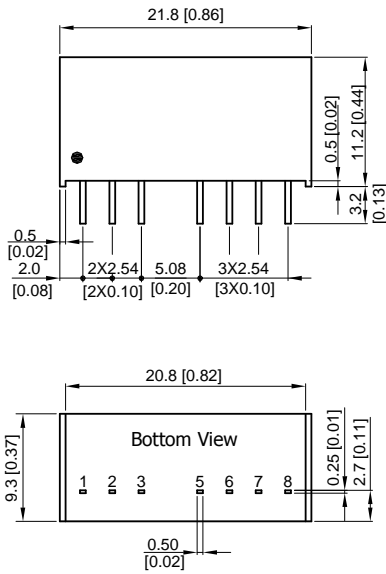

## Physical Characteristics

Case Size	:	21.8×9.3×11.2mm 0.86×0.37×0.44inches
Case Material	:	Non-Conductive Black Plastic
Weight	:	4.8g
Flammability	:	UL94V-0

Tolerance	Millimeters	Inches
	X.X±0.5	X.XX±0.02
	X.XX±0.25	X.XXX±0.01
Pin	±0.1	±0.004

## Pin Connections

Pin	Single Output	Dual Output
1	-Vin	-Vin
2	+Vin	+Vin
3	Remote On/Off	Remote On/Off
5	NC	NC
6	+Vout	+Vout
7	-Vout	Common
8	NC	-Vout

NC: No Connection